

Tersus GNSS AX4E05 Helix Antenna

Overview

The AX4E05 is a high performance GNSS antenna designed for high precision positioning service and offers superior satellite signal tracking, including GPS, GLONASS, GALILEO, BeiDou, as well as L-Band correction service. It could be used for applications as surveying and mapping, and various UAVs operations as aerial photography, remote sensing, infrastructure inspection, traffic control, and public security.

This helix antenna ensures a high phase center stability with centimeter level accuracy. Its high gain with ultralow signal loss, wide beam width for exceptional low elevation satellite tracking with symmetric radiation patterns effectively improve positioning accuracy even under challenging environments that has blockage.



Key Features

- ✓ Supports multiple constellations and frequencies
 - GPS L1, L2, L5
 - GLONASS L1, L2
 - BeiDou B1, B2, B3
 - Galileo E1, E5a, E5b
 - QZSS L1, L2, L5, L6
 - IRNSS L5
 - SBAS L1, L5
 - L-Band
- ✓ High stability and high repeatability at phase center with centimeter level accuracy
- ✓ High antenna gain having superior tracking performance at low elevation angles
- ✓ Improved signal filtering and excellent multipath rejection
- ✓ lightweight, low profile facilitates easier integration
- ✓ SMA-J connector

Tersus GNSS AX4E05 Helix Antenna

Technical Specifications

Performance

Signal Tracking:	
GPS L1, L2, L5; Galileo E1, E5a, E5b; SBAS L1, L5;	GLONASS L1, L2; QZSS L1, L2, L5, L6; L-Band
	BDS B1, B2, B3; IRNSS L5;
Nominal Impedance:	50Ω
Polarization:	RHCP
Axial Ratio:	≤3dB
Gain RHCP(maximum):	
1166-1278MHz:	2.6dBi
1559-1612MHz:	2.8dBi
L-Band:	1.5dBi
Azimuth Coverage:	360°(Omni-directional)

Mechanical

Size:	φ 43.6x40.8mm
Connector:	SMA-J
Weight:	≤30.5g
Mounting:	3-NO.3-48UNC Screws Fixed

Structure Overview/mm

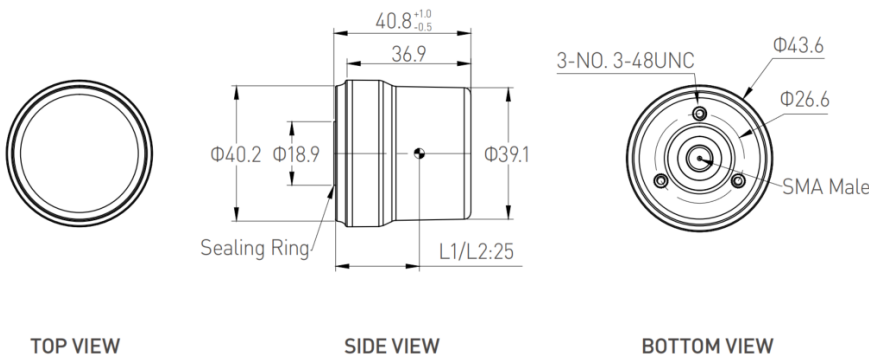

LNA

LNA Gain:	33±2dB (Typical)
Noise Figure:	≤2dB
Output VSWR:	≤2.0
Out of Band Rejection:	
Upper Band :	<1400MHz> 30dB <1450MHz> 33dB >1700MHz> 30dB
Lower Band :	<1000MHz> 41dB <1100MHz> 40dB <1130MHz> 28dB
Passband Ripple:	±2dB
Operation Voltage:	3.3V~12V DC
Operation Current:	≤ 55mA
Differential Propagation Delay :	≤ 5ns

Environmental

Operating Temperature:	-40°C ~ +70°C
Storage Temperature:	-55°C ~ +70°C
Humidity:	95% not condensing
Dust- & Waterproof:	IP67

Website: www.tersus-gnss.com
Sales Inquiry: sales@tersus-gnss.com
Technical Support: support@tersus-gnss.com

Information is subject to change without notice.
 © Copyright 2023 Tersus GNSS Inc.