

# Tersus GNSS

## AG992-Pro GNSS Auto-Steering System

### Overview

---

The Tersus AG992-Pro Auto-Steering System is an automatic steering system which uses high-torque motor control steering wheel. It integrates the advantages of convenient installation, large torque, high precision, low noise, low heat and quick debugging. It is suitable for various applications of tractors, harvesting machines, plant protection machinery, rice transplanters and other agricultural models.

The system includes a high-precision GNSS receiver with satellite-based Precise Point Positioning (PPP) service, a control tablet, a steering wheel motor and a high-performance Inertial Measurement Unit(IMU). It controls the vehicle and co-operates with/without a base station to form a whole machine control system for agriculture applications. It can be widely used for sowing, cultivating, trenching, ridging, spraying pesticide, transplanting, land consolidation, harvesting and other work scenarios.

### Key Features

---

- ✓ Supports multiple constellations and frequencies
  - GPS L1C/A, L2C, L2P, L5
  - GLONASS L1C/A, L2C/A
  - BeiDou B1, B2, B3, supports BDS-3
  - Galileo E1, E5a, E5b
  - QZSS L1C/A, L2C, L5
  - SBAS supports WAAS, EGNOS, GAGAN,SDCM, MSAS
- L-band
- ✓ Satellite-based PPP service (Tersus TAP)
- ✓ Small high-torque motor
- ✓ Highly integrated system
- ✓ 10.1" touch screen control tablet
- ✓ Auto-Steering error less than 2.5cm
- ✓ Without modification of the hydraulic system
- ✓ Simple & Fast installation
- ✓ Easy & Quick calibration procedures



# Tersus GNSS - TC100 Control Tablet

## Technical Specifications

### System

Operating System:	Android 6.0 / 9.0
CPU:	Quad-Core 1.5GHz
Memory:	2GB RAM + 16GB ROM
External Flash:	T-Flash , up to 64GB
LCD:	10.1" Capacitive Touch Screen
Resolution:	1024x600 pixels

### Communication

Wi-Fi:	2.4GHz IEEE 802.11 b/g/n
Cellular:	LTE-FDD B1/B2/B3/B4/B5/B7/B8 /B12/B13/B18/B19/B20/B25/B26/28 LTE-TDD B38/B39/B40/B41 WCDMA B1/B2/B4/B5/B6/B8/B19 GSM 850 / 900 / 1800 / 1900MHz
Bluetooth:	V4.2
USB:	USB 2.0 (host & debug) x1
Audio:	3.5mm Audio Jack for Audio
Serial Port:	RS232 x2, RS485 x1
CAN Port:	CAN x 1
Ethernet:	RJ45 (100M Ethernet) x1

### Electrical

Power Input:	9V~36V DC
Power failure detection:	supported
Power output:	12V DC x1

### Physical

Dustproof & Waterproof:	IP-67
Dimension:	281mmx181mmx42mm
Weight:	1.36kg
Operating Temperature:	-40 °C ~ +70 °C
Storage Temperature:	-45 °C ~ +80 °C



# Tersus GNSS

## - David30-TAP GNSS Receiver

### Technical Specifications

#### Performance

Frequencies:	GPS L1C/A, L2C, L2P, L5 GLONASS L1C/A, L2C/A BeiDou B1, B2, B3, supports BDS-3 Galileo E1, E5a, E5b QZSS L1C/A, L2C, L5 SBAS supports WAAS, EGNOS, GAGAN,SDCM, MSAS L-band
Single Point Positioning Accuracy (RMS):	
• Horizontal:	1.5m
• Vertical:	3.0m
Real Time Kinematic, RTK (RMS):	
• Horizontal:	8mm+1ppm
• Vertical:	15mm+1ppm
Timing Accuracy (RMS):	20ns
Velocity Accuracy (RMS):	0.03m/s
TAP positioning accuracy (RMS):	< 3cm
TAP convergence time:	3 minutes
TAP coverage:	Global
TAP signal stability:	99.99%
Initialization reliability:	> 99.99%
Correction:	RTCM 2.x/3.x, CMR/CMR+
Data Output:	NMEA-0183, Tersus Binary
Max. Update Rate:	20Hz
Storage:	Built-in 8GB

#### Communication

Serial ports:	RS-232 x 2
COM baud rate:	up to 921600bps
USB ports:	USB 2.0 OTG x 1
CAN ports:	CAN x 1
ANT connector:	TNC female x 1

#### Electrical & Physical

Input voltage:	5 ~ 36V DC
Power consumption:	3.6W (typical)
Dimension:	124x79.5x37mm
Weight:	≈ 360g

#### Environmental

Dustproof & Waterproof:	IP-67
Humidity:	95% not condensing
Operating Temperature:	-40 °C ~ +70 °C
Storage Temperature:	-40 °C ~ +85 °C



# Tersus GNSS

## - A10 GNSS Antenna

### Technical Specifications

#### Performance

Frequencies:	GPS L1, L2, L5, L-Band GLONASS L1, L2, L3 BeiDou B1, B2, B3 Galileo E1, E5a, E5b, E6 QZSS L1, L2, L5, L6 SBAS L1, L5 IRNSS L5
Impedance:	50Ω
Polarization:	RHCP
Axial Ratio:	≤3dB
Output VSWR:	≤2.0
Peak Gain:	4.5dBi
LNA Gain:	40dB (typical)
Noise Figure:	≤2.0dB
Operation Voltage:	3.3V~12V DC
Operation Current:	≤45mA
Group Delay Ripple:	<5ns
Phase Center Offset:	59.14mm
Phase Center Accuracy:	±2mm



#### Environmental

Dustproof & Waterproof:	IP-67
Humidity:	95% not condensing
Operating Temperature:	-40 °C ~ +85 °C
Storage Temperature:	-55 °C ~ +85 °C

#### Mechanical

Dimension:	φ 152x62.2mm
Connector:	TNC Female
Screw Hole for assembly:	BSW 5/8"×11, 12-14mm
Weight:	≤400g

#### Structure Overview

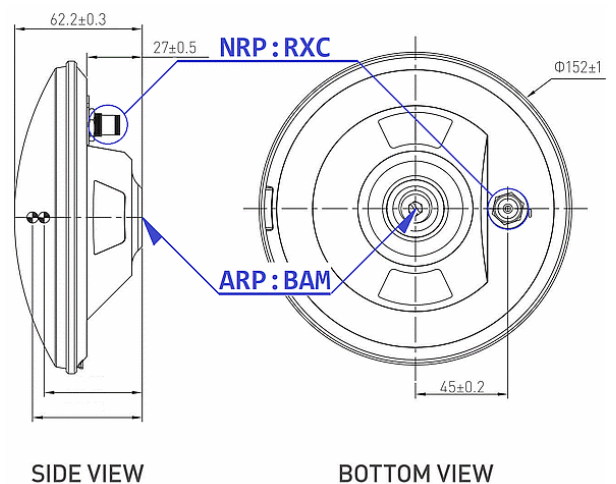

# Tersus GNSS - TES20 Motor Wheel

## Technical Specifications

### Motor Performance

Rated speed:	100 rpm
Rated torque:	10 N · m (typical)
Guaranteed continuous operation speed:	100 rpm
Maximum freewheel error:	0 (without reducer)
Supply voltage:	6V~18V DC
Rated current:	10A
Stall current:	25A
Rated voltage:	12V

### Communication

Communication protocol:	ModBUS
Communication interface:	RS232
Encoder resolution:	1000 lines
Encoder interface (protocol):	parallel, no protocol
Encoder maximum output rate:	200KHz

### Physical

Dimension:	φ 178x81mm (Motor)
	φ 410x32mm (Steering Wheel)
Weight:	5.25kg (Motor only)
	6.35kg (Motor and Wheel)
Material:	Aluminum alloy

### Environmental

Dustproof & Waterproof:	IP-65
Operating Temperature:	-40 °C ~ +105 °C (Motor)
Storage Temperature:	-45 °C ~ +105 °C (Motor)



**Website:** [www.tersus-gnss.com](http://www.tersus-gnss.com)  
**Sales Inquiry:** [sales@tersus-gnss.com](mailto:sales@tersus-gnss.com)  
**Technical Support:** [support@tersus-gnss.com](mailto:support@tersus-gnss.com)

Information is subject to change without notice.  
 © Copyright 2024 Tersus GNSS Inc.