

Tersus GNSS AX4E02 Full-Constellation Survey Antenna

Overview

The AX4E02 is a full-constellation survey antenna. It can receive GPS, GLONASS, BeiDou, Galileo, QZSS, SBAS and IRNSS signals, which can be used in land survey, marine survey, channel survey, seismic monitoring, bridge survey, container operation, agriculture applications, autonomous vehicles, and etc. The AX4E02 was calibrated in NGS and its high precision has been recognized.

The AX4E02 has high gain and wide beam width to ensure that connected GNSS receivers perform well at low elevation angle signals. The phase center of this antenna remains constant as the azimuth and the elevation angles of the satellites change. Signal reception is unaffected by the rotation of the antenna or satellite elevation, so placement and installation of the antenna can be completed with ease. It is ideal for challenging environments where high precision is needed, such as obstructed trees or constructions.

Key Features

- ✓ Supports multiple constellations and frequencies
 - GPS L1, L2, L5, L-Band
 - GLONASS L1, L2, L3
 - BDS B1, B2, B3
 - Galileo E1, E5a, E5b, E6
 - QZSS L1, L2, L5, L6
 - IRNSS L5
 - SBAS L1, L5
- ✓ An internal multi-path-rejection board eliminates multi-path interference errors
- ✓ Has a multi-feed design to ensure superposition of phase center and geometrical center, and minimize the influence of multipath errors
- ✓ IP67 rated water and dustproof design
- ✓ Internal lightning proof circuit protects LNA from being damaged by high voltage surges
- ✓ Very low noise figure



Tersus GNSS AX4E02 Full-Constellation Survey Antenna

Technical Specifications

Performance

Signal Tracking:	
GPS L1, L2, L5, L-Band; GLONASS L1, L2, L3; BDS B1, B2, B3; Galileo E1, E5a, E5b, E6; QZSS L1, L2, L5, L6; IRNSS L5; SBAS L1, L5	
Impedance:	50Ω
Polarization:	RHCP
Axial Ratio:	≤3dB
Peak Gain:	≤5.5dBi
Phase Center Offset:	59.14mm
Phase Center Accuracy:	±2mm

Mechanical

Size:	φ 152x62.2mm
Connector:	TNC Female
Weight:	≤5000g
Screw Hole for Assembly:	BSW 5/8" × 11, 12-14mm

Structure Overview/mm

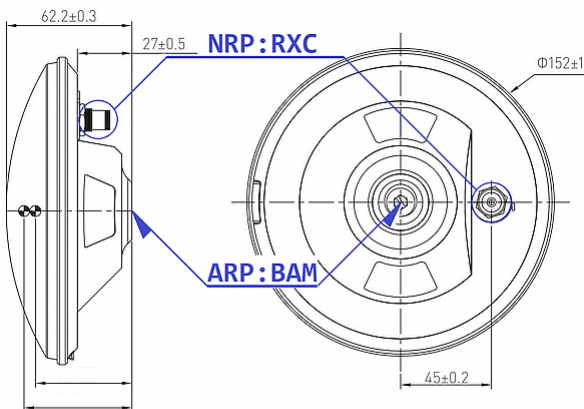

SIDE VIEW

BOTTOM VIEW

LNA

LNA Gain:	40dB (Typical)
Noise Figure:	≤2dB
Output VSWR:	≤2.0
Operation Voltage:	3.3V~12V DC
Operation Current:	≤ 45mA
Group Delay Ripple:	< 5ns

Environmental

Operating Temperature:	-40°C ~ +85°C
Storage Temperature:	-55°C ~ +85°C
Humidity:	95% not condensing
Dust- & Waterproof:	IP67

Website: www.tersus-gnss.com
Sales Inquiry: sales@tersus-gnss.com
Technical Support: support@tersus-gnss.com

Information is subject to change without notice.
 © Copyright 2023 Tersus GNSS Inc.